

# 80 W AIN Stripline Termination



Standards  
NF C 96-315  
MIL-DTL-39030



Substrate	AlN
Resistive film	Thick film
Tab	Ag
Protection film	Epoxy
Mounting flange/Plating	Cu/Ni
Tab attachment	Brazed with epoxy encapsulation

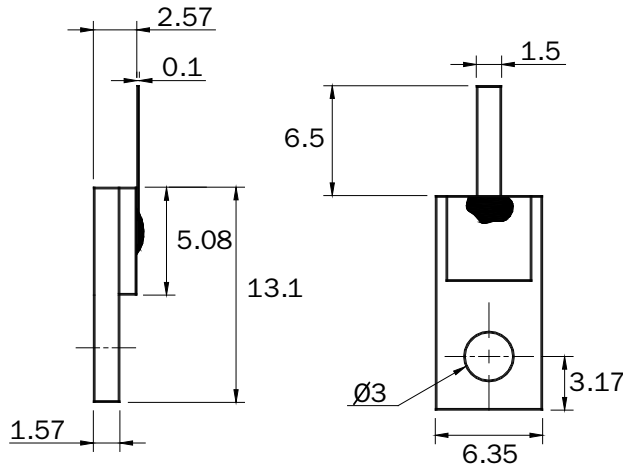
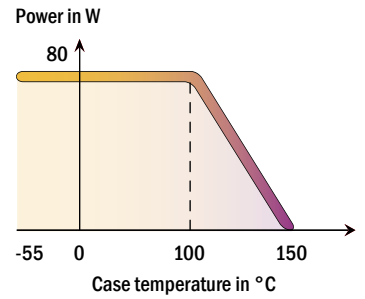

Dimensions in mm

mm	inch
0.1	0.004
1.5	0.059
1.57	0.062
2.57	0.101
3	0.118
3.17	0.125
5.08	0.200
6.35	0.250
6.5	0.256
13.1	0.516

P/N	Frequency (GHz)	Power (W)	Impedance ( $\Omega \pm 5\%$ )	Max VSWR
17-0458	6	80	50	1.20*

\* VSWR  $\leq$  1.10 at 3.5 GHz